

FILED
Date: 4-30-2008 By: kw
This survey consists of:
Map: M155-52
Narrative: _____
Corner Rpt: _____
DOUGLAS COUNTY
SURVEYOR

DECLARATION:

KNOW ALL PEOPLE BY THESE PRESENTS THAT JOHN C. AND ROSSIE MAE KENT, ARE THE OWNERS OF THE LAND REPRESENTED HEREON AND MORE PARTICULARLY DESCRIBED HEREIN AND HAVE CAUSED THE SAME TO BE PLATTED INTO PARCELS TOGETHER WITH EASEMENTS AS SHOWN.

JOHN C. KENT DATE _____

ROSSIE MAE KENT DATE _____

ACKNOWLEDGMENT:

STATE OF OREGON }
COUNTY OF DOUGLAS } ss.
KNOW ALL PEOPLE BY THESE PRESENTS, ON THIS _____ DAY OF _____, 20____, BEFORE ME A NOTARY PUBLIC IN AND FOR SAID STATE AND COUNTY, PERSONALLY APPEARED JOHN C. AND ROSSIE MAE KENT, WHO DID SAY THAT THEY ARE THE IDENTICAL PERSONS NAMED IN THE FOREGOING INSTRUMENT AND THAT THEY EXECUTED SAID INSTRUMENT FREELY AND VOLUNTARILY.

NOTARY: ELAINE BERG
NOTARY PUBLIC - OREGON
COMMISSION NO.: 405611
MY COMMISSION EXPIRES: JUNE 23, 2010

SURVEYOR'S CERTIFICATE:

I, RONALD A. QUIMBY, OREGON PROFESSIONAL LAND SURVEYOR NO. 1654, HEREBY CERTIFY THAT I HAVE CORRECTLY SURVEYED AND MARKED WITH PROPER MONUMENTS THE LAND SHOWN ON THE ANNEXED PLAT OF WHICH THE FOLLOWING IS A TRUE AND CORRECT DESCRIPTION:

ALL OF THAT LAND DESCRIBED IN INSTRUMENT NUMBERS 81-04393 AND 72-11219, DOUGLAS COUNTY DEED RECORDS, LOCATED IN THE NORTHWEST QUARTER OF SECTION 3, TOWNSHIP 27 SOUTH, RANGE 6 WEST, WILLAMETTE MERIDIAN, DOUGLAS COUNTY, OREGON.

NARRATIVE:

THE PURPOSE OF THIS SURVEY IS TO PARTITION ALL OF THAT LAND AS DESCRIBED IN INSTRUMENTS 81-04393 AND 72-11219, DOUGLAS COUNTY DEED RECORDS, INTO 3 PARCELS AS SHOWN HEREON. THE PROCEDURE WAS AS FOLLOWS:

MONUMENTS OF RECORD WERE TIED AND HELD AS SHOWN. THE MISSING CORNER ON THE WESTERLY BOUNDARY WAS ESTABLISHED BY PROPORTIONING BETWEEN FOUND MONUMENTS AND A MONUMENT WAS SET. MONUMENTS WERE THEN SET IN ORDER TO DELINEATE THE PARCEL BOUNDARIES AS SHOWN. THE BOUNDARY BETWEEN PARCELS 2 AND 3 WAS ESTABLISHED BY HOLDING THE WEST BOUNDARY OF THE WILLIAMS PIPELINE NATURAL GAS TRANSMISSION EASEMENT.

NOTE:

AT THE CLIENTS REQUEST, THIS PARTITION PLAT IS BEING FILED AS A RECORD OF SURVEY MAP.

LEGEND:

- SET 5/8" x 30" IRON ROD w/CAP MARKED "I.E. ENGINEERING" UNLESS OTHERWISE NOTED
- FOUND 5/8" IRON ROD UNLESS OTHERWISE NOTED
- () R1 RECORD AS PER RANCH 1 SUBDIVISION (VOL. 22, PG. 46)
- () R2 RECORD AS PER PARTITION PLAT 2002-0022
- () R3 RECORD AS PER INSTRUMENT NUMBER 81-04393

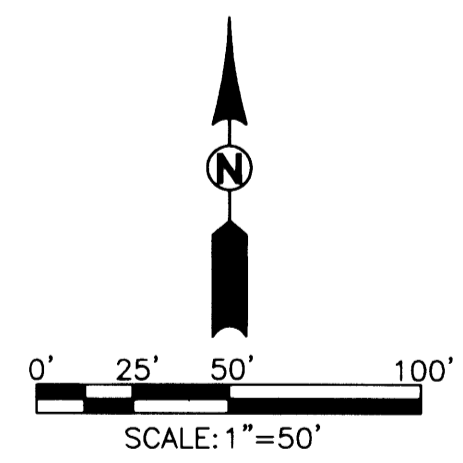

APPROVALS:

DOUGLAS COUNTY PLANNING DIRECTOR DATE _____

DOUGLAS COUNTY SURVEYOR DATE _____
I HEREBY CERTIFY THAT ALL TAXES AND SPECIAL ASSESSMENTS OR OTHER CHARGES REQUIRED BY LAW HAVE BEEN PAID.

DOUGLAS COUNTY TAX COLLECTOR DATE _____
FILED THIS _____ DAY OF _____, 20____, _____ O'CLOCK AM/PM

DOUGLAS COUNTY CLERK DATE _____

ZONE: RR
COMP. PLAN: RC2
WATER: UBWA
SEWER: ON-SITE

REGISTERED PROFESSIONAL LAND SURVEYOR
Ronald A. Quimby
OREGON
JULY 14, 1978
RONALD A. QUIMBY
1654
EXPIRES: 12/31/2008

**-LAND PARTITION-
RECORD OF SURVEY**
LYING IN THE NORTHWEST 1/4 SECTION 3,
TOWNSHIP 27 SOUTH, RANGE 6 WEST,
WILLAMETTE MERIDIAN, DOUGLAS COUNTY, OREGON

SURVEYED FOR: JIM KENT 481 BLANDS LN. ROSEBURG, OR 97470	SURVEYED BY: i.e. ENGINEERING 809 SE Pine Street Roseburg, Oregon 97470 PHONE (541) 673-0166 FAX (541) 440-9392 iemai@ieengineering.com
JOB NO: 2230-01	DWG. BY: BHK
SCALE: AS SHOWN	DATE: JULY, 2006
PM: BHK	PAGE: 1 OF 1

PLANNING DEPARTMENT FILE NO. 07-050

