

NOTE:

TRACT A IS A DRAINAGE DETENTION/DELINEATED WETLAND AREA THAT IS NOT AVAILABLE FOR RESIDENTIAL USE OR DEVELOPMENT AND SHALL BE OWNED AND MAINTAINED BY THE RIVERCREST ESTATES HOMEOWNERS ASSOCIATION, THEIR HEIRS AND ASSIGNS

LINE TABLE		
LINE	BEARING	LENGTH
L7	N37°24'47"W	18.46'
L8	N38°46'40"E	17.07'
L9	S01°44'28"E	16.82'
L10	S58°06'24"W	17.34'
L11	N28°13'31"W	19.69'
L12	S71°44'18"W	24.68'

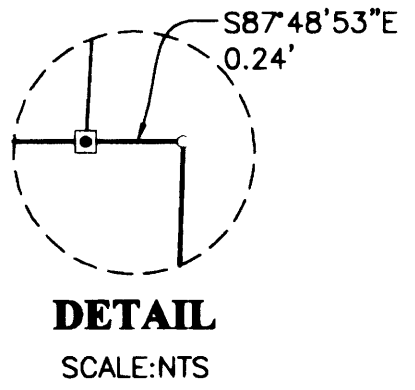

SEE PAGE 4

CURVE TABLE					
CURVE	CHORD BEARING	CHORD LENGTH	RADIUS	CURVE LENGTH	DELTA
C8	N81°42'00"W	89.47'	420.00'	89.64'	12°13'45"
C9	S00°43'46"E	19.93'	600.00'	19.93'	1°54'10"
C10	S00°43'46"E	20.82'	627.00'	20.82'	1°54'10"
C11	S00°43'46"E	19.03'	573.00'	19.03'	1°54'10"
C12	S00°50'16"E	44.58'	50.00'	46.20'	52°56'35"
C13	S45°17'56"W	33.65'	50.00'	34.32'	39°19'51"
C14	S85°38'10"W	35.30'	50.00'	36.08'	41°20'37"
C15	N54°47'50"W	32.38'	50.00'	32.98'	37°47'23"
C16	N12°31'28"W	39.68'	50.00'	40.80'	46°45'21"
C17	N37°47'22"E	45.30'	50.00'	47.01'	53°52'18"
C18	N79°38'59"W	127.82'	450.00'	128.26'	16°19'48"
C19	N58°06'35"W	208.19'	450.00'	210.09'	26°45'00"
C20	N58°15'09"W	139.88'	480.00'	140.38'	16°45'25"
C21	N56°46'49"W	104.96'	420.00'	105.23'	14°21'19"
C22	N47°18'16"W	43.04'	480.00'	43.05'	5°08'21"
C23	N47°10'07"W	35.67'	420.00'	35.68'	4°52'04"
C24	S50°17'07"E	92.86'	480.00'	93.00'	11°06'04"
C25	S61°39'33"E	244.53'	420.00'	248.12'	33°50'55"
C26	S73°56'08"E	101.72'	480.00'	101.91'	12°09'53"
C27	S51°50'27"E	111.33'	450.00'	111.62'	14°12'43"
C28	S69°08'53"E	159.40'	450.00'	160.24'	20°24'09"
C34	N81°34'28"W	87.71'	480.00'	87.83'	10°29'02"
C36	N66°16'29"W	330.44'	450.00'	338.35'	43°04'48"
C37	S61°25'23"E	258.45'	450.00'	262.14'	33°22'36"
C38	S50°13'53"E	80.46'	420.00'	80.59'	10°59'37"
C39	S57°15'17"E	22.38'	420.00'	22.38'	3°03'10"
C40	S68°40'56"E	144.44'	420.00'	145.16'	19°48'09"

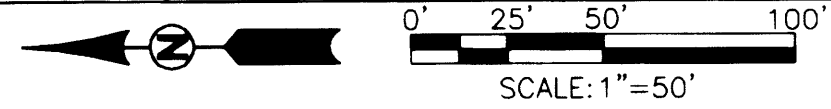

- LEGEND**
- DENOTES A 5/8" x 30" IR w/YELLOW CAP MARKED "I.E. ENGINEERING" TO BE SET WITH THE TIME SPECIFIED IN THE SURVEYOR'S CERTIFICATE SET ON 9-22-2006
 - FOUND 5/8" IRON ROD UNLESS OTHERWISE NOTED
 - FOUND 3/4" BOLT
 - △ CALCULATED POSITION

()R1 RECORD AS PER VOL. 21, PG. 41
()R2 RECORD AS PER M132-22
()R3 RECORD AS PER M148-48

SEE PAGE 2

REGISTERED PROFESSIONAL LAND SURVEYOR

Ronald A. Gurney

OREGON
JULY 14, 1978
RONALD A. GURNEY
1984

EXPIRES: 12/31/2006

RIVERCREST ESTATES 2, PHASE 1
LYING IN THE NW AND SW 1/4S OF SECTION 10, TOWNSHIP 28 SOUTH RANGE 6 WEST, WILLAMETTE MERIDIAN, DOUGLAS COUNTY, OREGON

SURVEYED FOR:
HAYDEN HOMES
2622 SW GLACIER PLACE SUITE 110
REDMOND, OR 97756

SURVEYED BY:
i.e. ENGINEERING
505 SE Main Street
Roseburg, Oregon 97470
PHONE (541) 673-0166
FAX (541) 440-9392
iemail@ieengineering.com

DWG. BY: JAC

SCALE: AS SHOWN DATE: JAN., 2006 JOB NO: 1944-03 PAGE: 3 OF 4