

**NOTES:**  
BASIS OF BEARING IS FROM POINT A ALONG THE WESTERLY BOUNDARY TO POINT B, ALL MONUMENTATION RECORD PER PREVIOUS "I.E. ENGINEERING" SURVEY "CLEARWATER SUBDIVISION PHASE 1."

LOTS 14 AND 28-37 SUBJECT TO 50' RIPARIAN SETBACK FROM DEER CREEK AND A 25' RIPARIAN SETBACK FROM RAMP CREEK.

**NOTE A:**  
INTERSECTION OF EASEMENT AND WESTERLY RIGHT-OF-WAY OF OAKBRIAR AVE. BEARS N32°45'13"E 1.38' FROM SET MONUMENT.

**NOTE B:**  
INTERSECTION OF EASEMENT AND THE WESTERLY BOUNDARY BEARS S03°52'10"W 29.45' FROM THE NORTHEAST CORNER OF LOT 11 OF CLEARWATER SUBDIVISION PHASE 1.

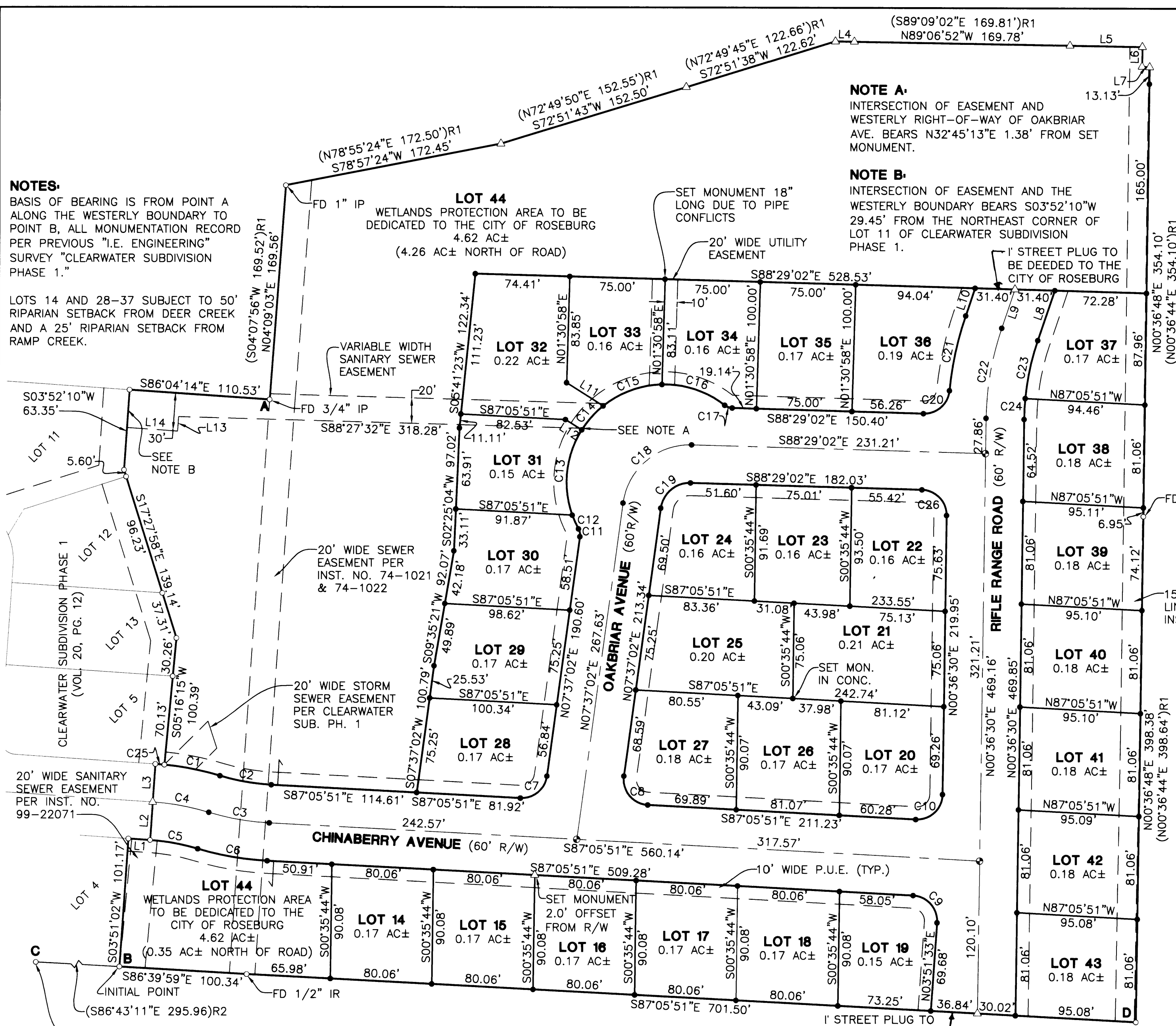

LINE TABLE		
LINE	BEARING	LENGTH
L1	N86°08'58"W	17.09'
L2	N03°51'02"E	30.00'
L3	N03°51'02"E	30.00'
L4	N89°07'44"W	14.86'
	(N89°09'54"W	14.86')R1
L5	N89°06'33"W	57.08'
	(S89°08'43"E	57.09')R1
L6	N00°51'51"E	15.43'
	(S00°51'17"W	15.42')R1
L7	N86°25'56"W	5.99'
	(S86°28'08"E	5.99')R1
L8	N18°41'37"E	41.56'
L9	N18°41'37"E	32.28'
L10	N18°41'37"E	22.99'
L11	S57°45'37"E	34.15'
L12	S57°45'37"E	15.12'
L13	S03°52'10"W	11.47'
L14	N86°04'14"W	40.00'

CURVE TABLE				
CURVE	CHORD BEARING	CHORD LENGTH	RADIUS	CURVE LENGTH
C1	N78°48'29"W	44.67'	230.00'	44.74'
C2	S80°10'00"E	41.03'	170.00'	41.13'
C3	S80°10'00"E	48.27'	200.00'	48.39'
C4	N79°41'34"W	44.98'	200.00'	45.08'
C5	N79°41'34"W	38.24'	171.42'	38.32'
C6	S80°10'00"E	55.51'	230.00'	55.64'
C7	N50°15'36"E	27.10'	20.00'	29.77'
C8	S39°44'24"E	29.42'	20.00'	33.06'
C9	N41°37'09"W	28.52'	20.00'	31.75'
C10	N46°45'19"E	28.84'	20.00'	32.22'
C11	N10°35'50"W	6.25'	10.00'	6.36'
C12	S24°21'52"E	11.94'	77.00'	11.95'
C13	S06°09'40"W	67.70'	77.00'	70.09'
C14	S41°42'46"W	25.35'	77.00'	25.46'
C15	S69°47'23"W	49.13'	77.00'	50.00'
C16	N71°49'50"W	52.10'	77.00'	53.15'
C17	S70°16'10"E	6.25'	10.00'	6.36'
C18	S49°34'00"W	70.86'	53.00'	77.61'
C19	S49°34'00"W	30.75'	23.00'	33.68'
C20	N48°25'30"E	27.33'	20.00'	30.08'
C21	S12°02'42"W	60.38'	258.33'	60.52'
C22	S09°41'04"W	72.03'	228.33'	72.34'
C23	S11°59'00"W	46.74'	200.00'	46.85'
C24	S02°54'18"W	16.53'	200.00'	16.53'
C25	N85°15'54"W	7.10'	230.00'	7.10'
C26	S43°56'16"E	28.06'	20.00'	31.10'

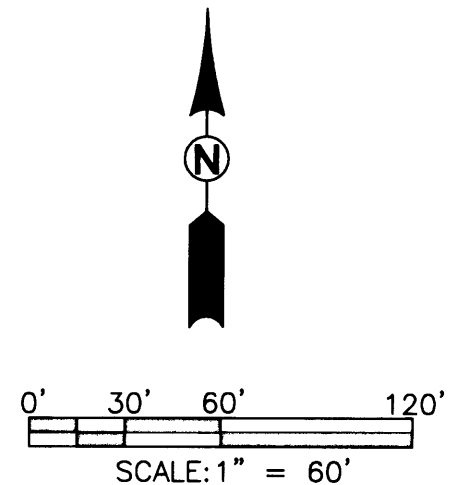

**SIDEWALK NOTE:**  
IF SIDEWALKS HAVE NOT BEEN CONSTRUCTED AFTER TWO YEARS FROM THE DATE THE FINAL SUBDIVISION PLAT WAS FILED, THE CITY OF ROSEBURG WILL REQUIRE ALL PARCELS TO DO SO AT THAT TIME.

- LEGEND**
- SET 5/8" x 30" IR w/CAP MARKED "I.E. ENGINEERING" UNLESS OTHERWISE NOTED
  - FOUND 5/8" IRON ROD UNLESS OTHERWISE NOTED
  - △ CALCULATED POSITION
  - SET MONUMENT IN MONUMENT BOX PER CITY OF ROSEBURG STANDARDS
- ( )R1 RECORD AS PER M124-26  
( )R2 RECORD AS PER VOL. 20, PG. 12

**REGISTERED PROFESSIONAL LAND SURVEYOR**  
*Jerry Lee Estabrook*  
**OREGON**  
JUNE 30, 1995  
**JERRY LEE ESTABROOK**  
2703  
EXPIRES: 12/31/2005

**CLEARWATER SUBDIVISION PHASE 2**  
LYING IN THE NW 1/4 OF SECTION 20, TOWNSHIP 27 SOUTH, RANGE 5 WEST, WILLAMETTE MERIDIAN, DOUGLAS COUNTY, OREGON

<b>SURVEYED FOR:</b> JERRY & DEBRA TABOR 615 DAIRY LOOP RD. ROSEBURG, OREGON 97470	<b>SURVEYED BY:</b> <b>i.e.</b> ENGINEERING 741 SE Jackson Street Roseburg, Oregon 97470 PHONE (541) 673-0166 FAX (541) 440-9392 iemail@ieengineering.com
SCALE: AS SHOWN	DATE: DEC., 2003
DWG. BY: MLJ	JOB NO: 859-10
PAGE: 1 OF 2	

**SURVEYOR'S CERTIFICATE:**

I, JERRY LEE ESTABROOK, OREGON PROFESSIONAL LAND SURVEYOR NO. 2703, HEREBY CERTIFY THAT I HAVE CORRECTLY SURVEYED AND MARKED WITH PROPER MONUMENTS THE LAND SHOWN ON THE ANNEXED PLAT OF WHICH THE FOLLOWING IS A TRUE AND CORRECT DESCRIPTION.

A PARCEL OF LAND LOCATED IN THE NORTHWEST 1/4 OF SECTION 20, TOWNSHIP 27 SOUTH, RANGE 5 WEST, WILLAMETTE MERIDIAN, DOUGLAS COUNTY, OREGON, BEING MORE PARTICULARLY DESCRIBED AS FOLLOWS:

BEGINNING AT A 5/8" IRON ROD AT THE SOUTHEAST CORNER OF LOT 4 OF CLEARWATER SUBDIVISION PHASE 1 A SUBDIVISION OF RECORD IN THE DOUGLAS COUNTY SURVEYOR'S OFFICE FROM WHICH THE INITIAL POINT OF SAID SUBDIVISION BEARS NORTH 86°43'11" WEST 295.96 FEET; THENCE SOUTH 86°39'59" EAST 100.34 FEET TO A 1/2" IRON ROD; THENCE SOUTH 87°05'51" EAST 701.50 FEET TO A 5/8" IRON ROD; THENCE NORTH 00°36'48" EAST 398.38 FEET TO A 1 1/4" IRON PIPE; THENCE NORTH 00°36'48" EAST 354.10 TO A POINT; THENCE NORTH 86°25'56" WEST 5.99 FEET TO A POINT; THENCE NORTH 00°51'51" EAST 15.43 FEET TO A POINT; THENCE NORTH 89°06'33" WEST 57.08 FEET TO A POINT; THENCE NORTH 89°06'52" WEST 169.78 FEET TO A POINT; THENCE NORTH 89°07'44" WEST 14.86 FEET TO A POINT; THENCE SOUTH 72°51'38" WEST 122.62 FEET TO A POINT; THENCE SOUTH 72°51'43" WEST 152.50 FEET TO A POINT; THENCE SOUTH 78°57'24" WEST 172.45 FEET 3/4" IRON PIPE; THENCE SOUTH 04°09'03" WEST 169.56 FEET 3/4" IRON PIPE; THENCE NORTH 86°04'14" WEST 110.53 FEET 5/8" IRON ROD; THENCE SOUTH 03°52'10" WEST 63.35 FEET 5/8" IRON ROD; THENCE SOUTH 17°27'58" EAST 139.14 FEET 5/8" IRON ROD; THENCE SOUTH 05°16'15" WEST 100.39 FEET 5/8" IRON ROD; THENCE ALONG THE ARC OF A 230.00 FOOT RADIUS CURVE TO THE LEFT 7.10 FEET, THE CHORD OF WHICH BEARS NORTH 85°15'54" WEST 7.10 FEET TO A 5/8" IRON ROD; THENCE SOUTH 03°51'02" WEST 60.00 FEET TO A 5/8" IRON ROD; THENCE NORTH 86°08'58" WEST 17.09 FEET TO A 5/8" IRON ROD; THENCE SOUTH 03°51'02" WEST 101.17 FEET TO THE POINT OF BEGINNING.

SAID PARCEL CONTAINING 12.24 ACRES MORE OR LESS.

**NARRATIVE:**

THE PURPOSE OF THIS SURVEY WAS TO SUBDIVIDE THE AFOREMENTIONED PARCEL AS SHOWN HEREIN. THE PROCEDURE WAS AS FOLLOWS: WE TIED EXISTING MONUMENTATION AS SHOWN HEREIN. WE THEN HELD A LINE THROUGH FOUND MONUMENTS ON THE EASTERLY BOUNDARY OF SAID PARCEL PROLONGED RECORD DISTANCE TO THE NORTH. WE THEN HELD THAT CALCULATED POSITION AND THE FOUND MONUMENT AT THE NORTHWESTERLY CORNER AND CALCULATED CORNERS ALONG THE NORTHERLY BOUNDARY BY COMPLETING A COMPASS ADJUSTMENT. WE THEN HELD THE MONUMENTS ON THE WESTERLY BOUNDARY OF SAID PARCEL AND THE INITIAL POINT OF CLEARWATER PER THE PREVIOUS I.E. ENGINEERING SURVEY "CLEARWATER SUBDIVISION PHASE 1" WHICH IS ALSO THE BASIS OF BEARING FOR THIS PLAT. WE THEN SUBDIVIDED AND SET MONUMENTS AS SHOWN HEREIN.

**TAX COLLECTOR STATEMENT:**

I HEREBY CERTIFY THAT TAXES AND SPECIAL ASSESSMENTS OR OTHER CHARGES REQUIRED BY LAW HAVE BEEN PAID.

Sandra K. Cooney 5/4/04  
 DOUGLAS COUNTY TAX COLLECTOR DATE

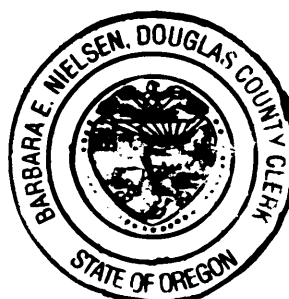

**ZONE:** MR-18  
**COMP. PLAN:** MEDIUM DENSITY MULTI-FAMILY RESIDENTIAL  
**WATER:** CITY OF ROSEBURG  
**SEWER:** R.U.S.A.

**APPROVALS:**

[Signature] 4/27/2004  
 PLANNING COMMISSION CHAIRMAN DATE

[Signature] 4-28-04  
 COMMUNITY DEVELOPMENT DIRECTOR DATE

[Signature] 04/21/04  
 PUBLIC WORKS DIRECTOR DATE

[Signature] 4-29-04  
 DOUGLAS COUNTY SURVEYOR DATE

[Signature] 5-3-04  
 DOUGLAS COUNTY ASSESSOR DATE

[Signature] 5-4-04  
 DOUGLAS COUNTY COMMISSIONER DATE

[Signature] 5/3/04  
 DOUGLAS COUNTY COMMISSIONER DATE

FILED THIS 4<sup>TH</sup> DAY OF MAY, 2004, 1:26 O'CLOCK PM  
 BARBARA E. NIELSEN  
 DOUGLAS COUNTY CLERK

**DECLARATION:**

KNOW ALL PEOPLE BY THESE PRESENTS THAT JERRY L. TABOR BUILDING, INC. IS THE OWNER OF THE LAND REPRESENTED HEREON AND MORE PARTICULARLY DESCRIBED HEREIN AND HAS CAUSED THE SAME TO BE PLATTED BY THE NAME OF "CLEARWATER SUBDIVISION PHASE 2" TOGETHER WITH EASEMENTS AS SHOWN AND DO HEREBY DEDICATE TO THE PUBLIC USE FOREVER THE STREETS AND TO THE CITY OF ROSEBURG THE LAND DESIGNATED AS WETLAND PROTECTION AREA (LOT 44) AS SHOWN HEREON.

[Signature] 3/16/04  
 JERRY L. TABOR (PRESIDENT) DATE

**ACKNOWLEDGMENT:**

STATE OF OREGON }  
 COUNTY OF DOUGLAS } ss.

KNOW ALL PEOPLE BY THESE PRESENTS, ON THIS 16<sup>TH</sup> DAY OF March, 2004, BEFORE ME A NOTARY PUBLIC IN AND FOR SAID STATE AND COUNTY, PERSONALLY APPEARED JERRY L. TABOR, WHO DID SAY THAT HE IS THE IDENTICAL PERSON NAMED IN THE FOREGOING INSTRUMENT AND THAT HE EXECUTED SAID INSTRUMENT FREELY AND VOLUNTARILY.

[Signature]  
 NOTARY: ELAINE BERG  
 NOTARY PUBLIC - OREGON  
 COMMISSION NO.: 358908  
 MY COMMISSION EXPIRES: JUNE 23, 2006

**FIELD CREW:** RYAN PALMER, JIM FERRIS, AND DEREK FEIGEL

**EQUIPMENT:** NIKON TOTAL STATION AND TDS RECON DATA COLLECTOR

**OFFICE:** JERRY ESTABROOK

**DRAFTING:** MICHAEL JONES

**NOTE:** SUBJECT TO COVENANTS AS RECORDED IN BOOK \_\_\_\_\_ PG. \_\_\_\_\_ INSTR. # 2004-010614 OF DEED RECORDS OF DOUGLAS COUNTY.

PLANNING DEPARTMENT FILE NO. S-01-01

<b>REGISTERED PROFESSIONAL LAND SURVEYOR</b> <u>[Signature]</u> <b>OREGON</b> JUNE 30, 1995 <b>JERRY LEE ESTABROOK</b> 2703 EXPIRES: 12/31/2005	<b>CLEARWATER SUBDIVISION PHASE 2</b> LYING IN THE NW 1/4 OF SECTION 20, TOWNSHIP 27 SOUTH, RANGE 5 WEST, WILLAMETTE MERIDIAN, DOUGLAS COUNTY, OREGON	
	<b>SURVEYED FOR:</b> JERRY & DEBRA TABOR 615 DAIRY LOOP RD. ROSEBURG, OREGON 97470	<b>SURVEYED BY:</b> <b>i.e.</b> <b>ENGINEERING</b> 741 SE Jackson Street Roseburg, Oregon 97470 PHONE (541) 673-0166 FAX (541) 440-9392 iemail@ieengineering.com
SCALE: AS SHOWN	DATE: DEC., 2003	JOB NO: 859-10
		PAGE: 2 OF 2

VOL. 21 PAGE 21B

VOL. 21 PAGE 21B