

DETAIL 'A'

- MATERIAL LIST
- 1 - SADDLE THRUST BLOCK
 - 1 - 8"x6"x8"x6" FLANGE CROSS
 - 1 - 8"x6"x8" MJ x FL x MJ TEE
 - 1 - 4" FLG x MJ VALVE
 - 1 - 2" VALVE
 - 1 - 2" BLOW-OFF ASSEMBLY
 - 1 - FIRE HYDRANT ASSEMBLY

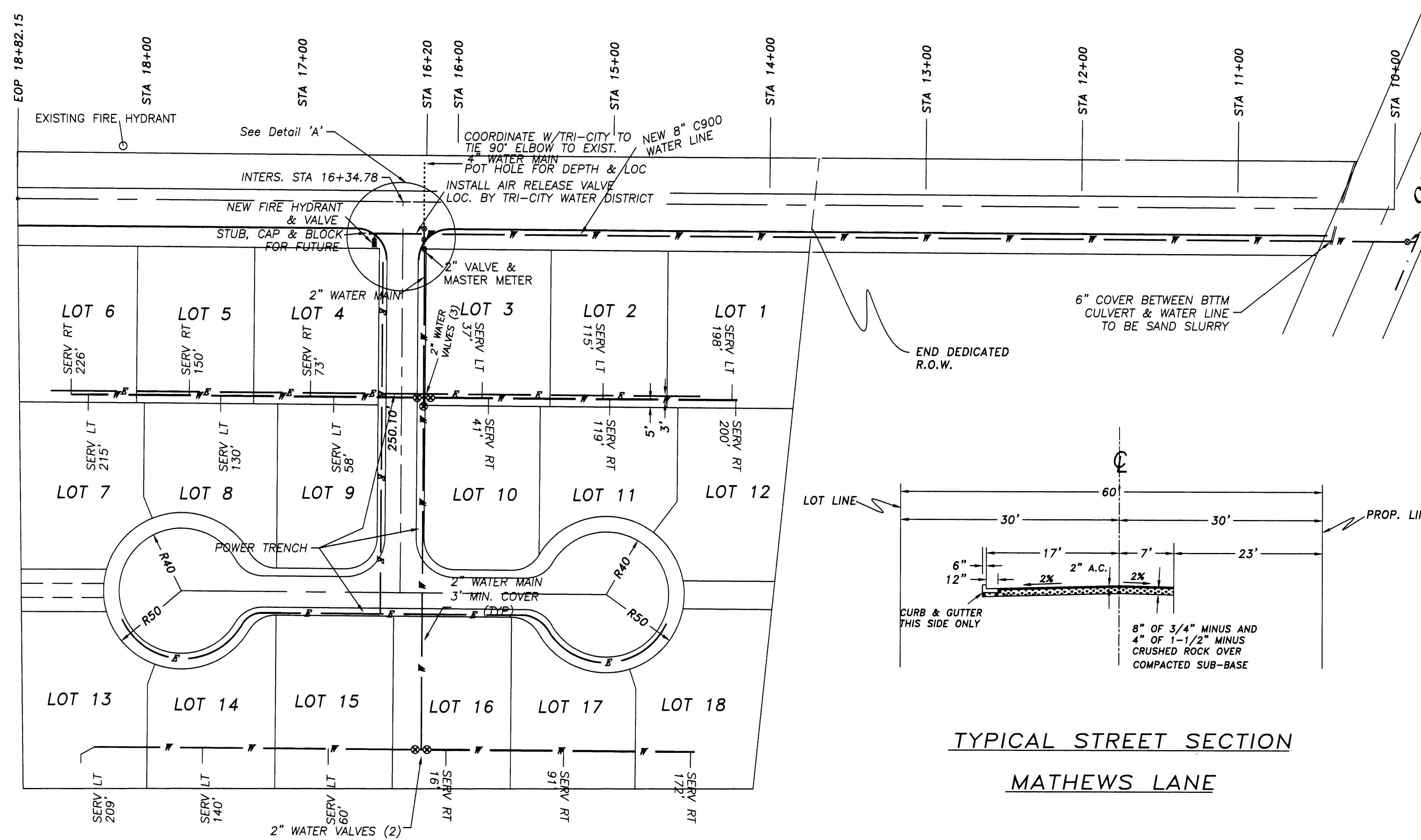

TYPICAL STREET SECTION
 MATHEWS LANE

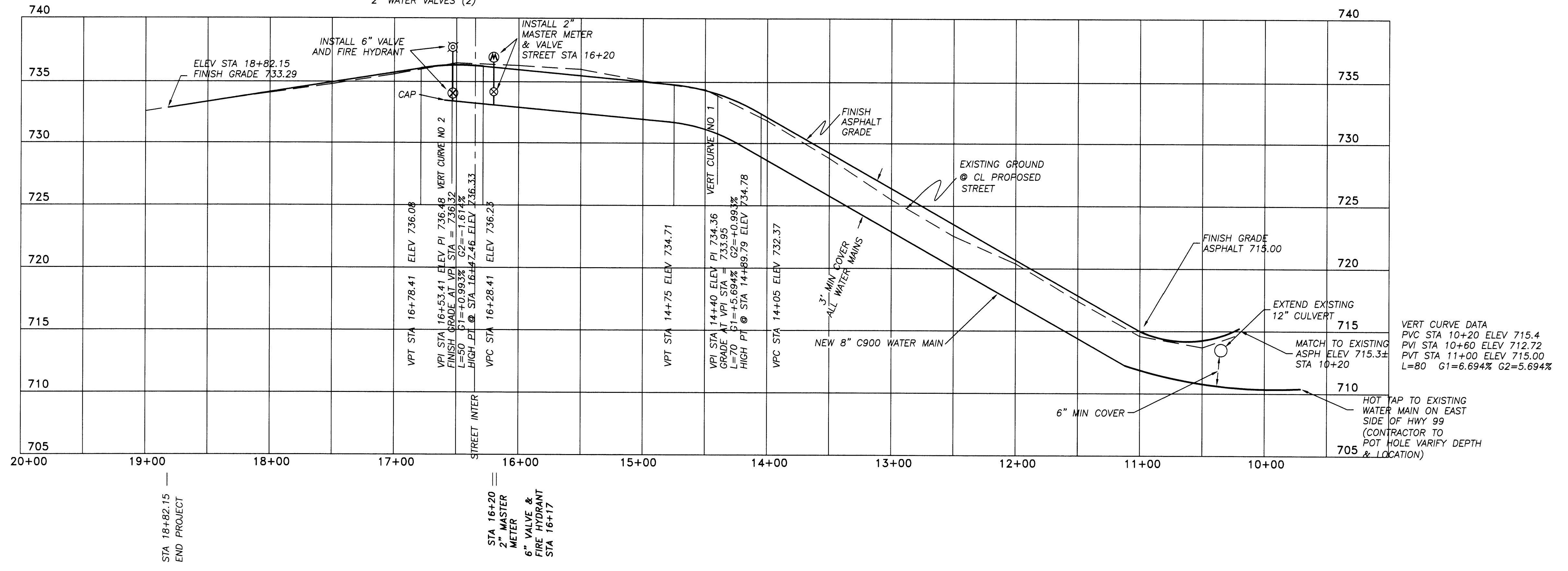

SCALE
 1" = 50' HORIZONTAL
 1" = 5' VERTICAL



NOTE:
 HOT TAP 6" LINE WITH A
 6" VALVE & LINE, FROM 6"
 VALVE BUSH UP TO 8" AS
 PER TRI-CITY WATER DIST.

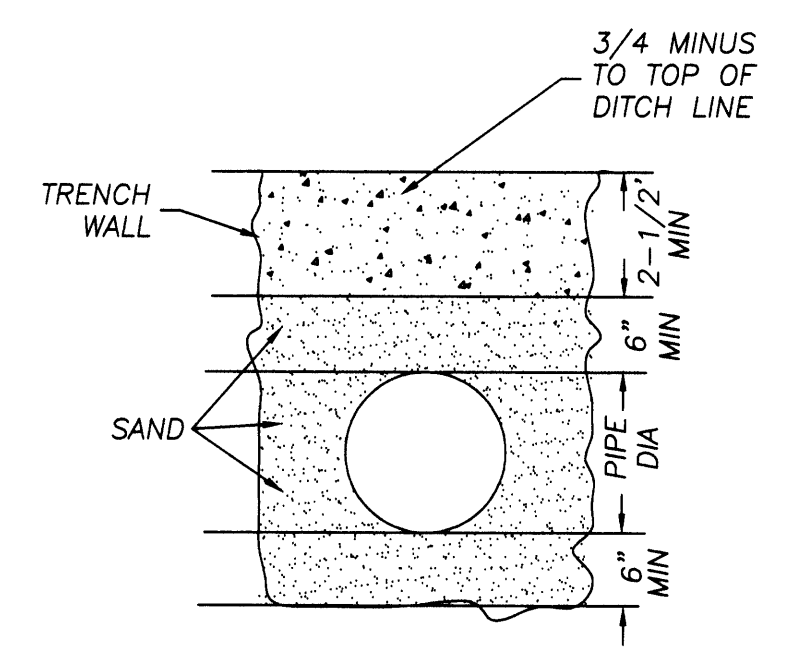

TYPICAL WATER MAIN SEC.

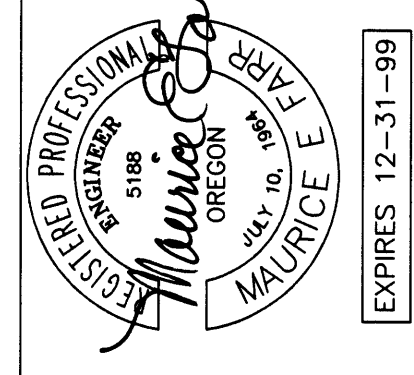

STREET AND WATER PLAN & PROFILE
 MATHEWS LANE FROM STA 10+63.13 TO 18+82.15

MATHEWS MANOR
 MOBILE HOME PARK

FOR: MATHEWS MANOR L.L.C.
 882 NW GARDEN VALLEY BLVD
 ROSEBURG, OR 97470

DAVID J. PERDUE
 PROFESSIONAL
 LAND SURVEYING
 163 TRAYLOR ROAD
 RIDGELAND, OREGON 97469

DATE: 8-10-99
 JOB #: 99-007
 FILE SHEET: 2-STRETLING
 SHEET # 2 of 6