

PIPE LIST & DRIVEWAY TYPICAL SECTION

PIPE LIST

STATION	DIAMETER	LENGTH	MATERIALS			TRENCH EXC. CU. YDS.	REMARKS STRUTTED END TREATMENT IMPERFECT TRENCH, ETC.
			ALUMINUM	GALV. STEEL	CONCRETE		
85+80	18"	24'			✓	1	EXTEND CULVERT PIPE
90+30	12"	40'		16.16	✓	2	"
92+39	18"	33'			✓	3	EXTEND
98+85	18"	28'		16.16	✓	2	"
99+40	24"	118'			✓	58	"
102+32	12"	36'		16.16	✓	2	"
105+00	18"	42'			✓	1	EXTEND
110+45	18"	52'			✓	12	"
113+45	24"	16'			✓	3	"
115+35	24"	36'			✓	3	"
120+55	12"	36'		16.16	✓	2	"
126+25	12"	40'		" "	✓	2	"
127+35	24"	36'			✓	2	EXTEND
135+40	12"	42'		16.16	✓	6	EXTEND
140+98	12"	36'		" "	✓	2	"
148+10	18"	104'			✓	44	"
149+30	18"	60'		16.16	✓	15	"
150+55	18"	40'			✓	4	EXTEND
155+15	18"	50'			✓	10	"
155+15	18"	44'			✓	2	"
156+30	12"	48'		16.16	✓	2	"
159+15	12"	24'		16.16	✓	1	"
159+55	18"	50'			✓	10	EXTEND
160+80	12"	24'		16.16	✓	1	"
161+90	18"	56'			✓	24	EXTEND
161+90	18"	44'			✓	15	"
162+85	12"	44'		" "	✓	2	"
163+90	12"	36'		" "	✓	2	"
168+50	12"	24'			✓	5	"
169+50	12"	49'			✓	14	CONDUIT
175+85	18"	52'			✓	18	EXTEND CULVERT PIPE
178+50	36"	42'			✓	15	"
181+95	18"	28'		" "	✓	7	"
181+95	18"	24'		" "	✓	4	EXTEND
190+30	18"	40'			✓	4	"
197+40	12"	40'		16.16	✓	2	"
204+40	12"	36'		" "	✓	2	"
205+10	18"	40'		" "	✓	3	"
209+85	12"	24'		" "	✓	1	"
213+54	18"	40'			✓	2	EXTEND
215+45	12"	32'		16.16	✓	2	"
218+50	18"	92'			✓	33	"
220+00	12"	32'		16.16	✓	2	"
224+00	18"	36'			✓	2	EXTEND
224+10	24"	36'			✓	2	"
225+85	12"	30'		16.16	✓	2	"
229+70	12"	40'		" "	✓	2	"
230+15	18"	48'		" "	✓	3	"
233+15	18"	44'			✓	6	EXTEND
236+35	18"	24'		16.16	✓	2	"
241+90	18"	40'		" "	✓	3	"
249+38	18"	112'			✓	80	"
253+76	18"	116'			✓	101	"

STATIONS & LENGTH OF PIPES TO BE VERIFIED IN FIELD.

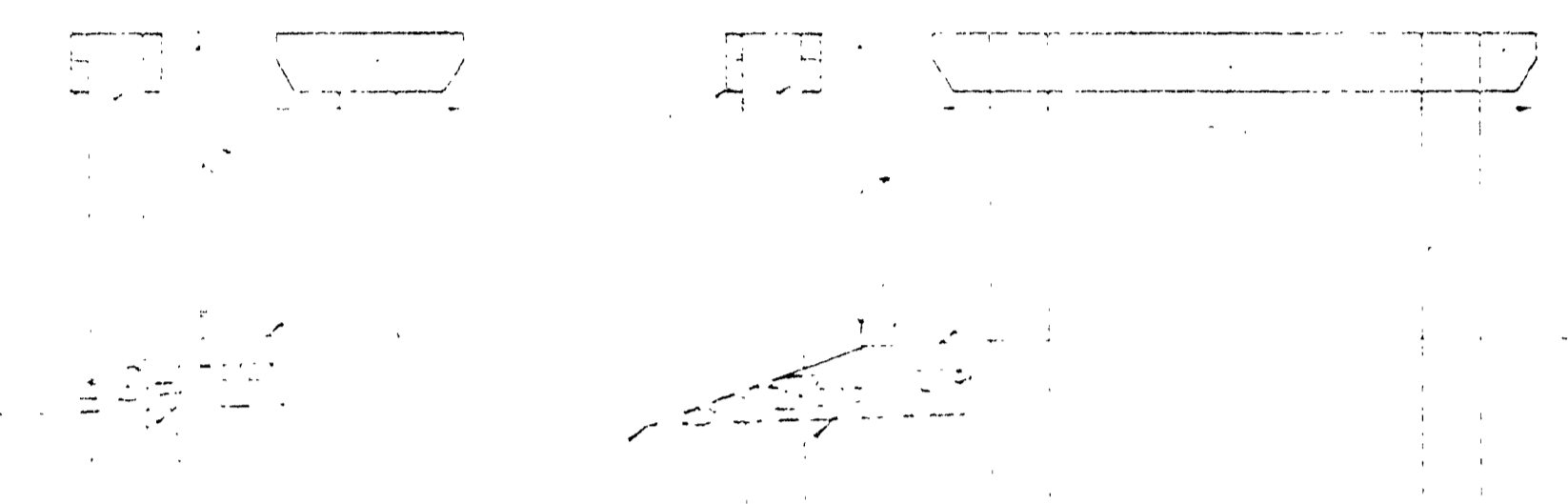

TYPICAL MAIL BOX STAND

BASE TO MATCH
Slope on standard
Multiple unit

TYPICAL SECTION
RURAL DRIVEWAY & ROAD APPROACH STANDARD

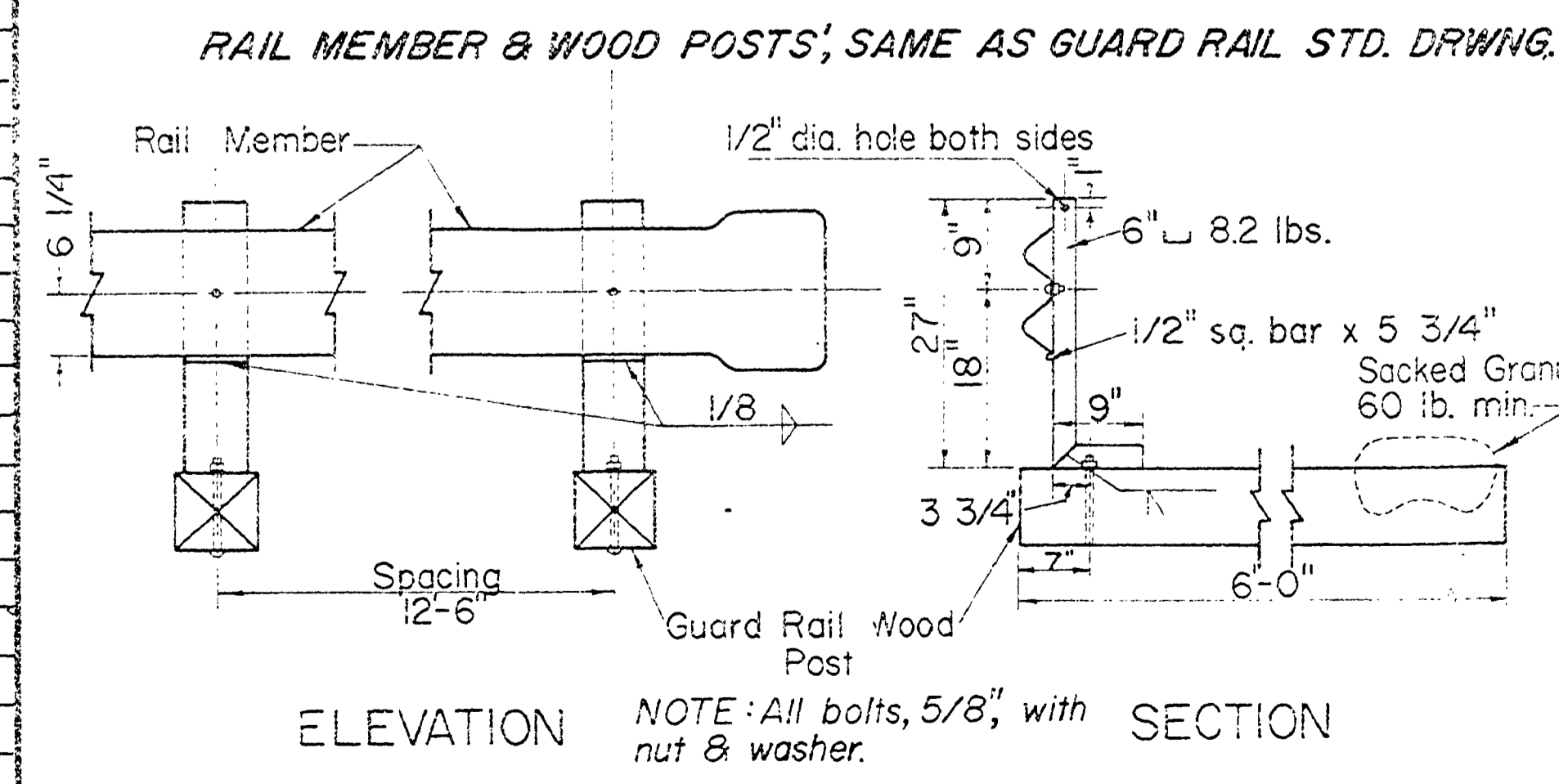

RAIL MEMBER & WOOD POSTS; SAME AS GUARD RAIL STD. DRAWING.

ELEVATION SECTION
NOTE: All bolts, 5/8", with nut & washer.

BARRICADE, TYPE TWO

Job Name NORTH UMPQUA HWY
 Job Number RD #4
 Date April 1969
 Douglas County Road Dept
 Standard Pipe List &
 Rural Driveway
 Date December 7, 1967
 George E. Graube, County Engineer

RD #4
 RD #4
 35