

LAND PARTITION

IN PARCEL 1, LAND PARTITION #97-0092 SE
 BEING IN THE EAST 1/2, SEC. 8, THE SW 1/4 OF SEC. 9 & THE SW 1/4 OF THE SW 1/4, SEC. 5, T. 25 S., R. 7 W., W. M.
 DOUGLAS COUNTY, OREGON - APRIL 2004 - PLANNING FILE #03-083

DECLARATION:

KNOW ALL PEOPLE BY THESE PRESENTS THAT JOHN D. AND PAMELA J. THENNES DO HEREBY DECLARE THAT THEY ARE THE OWNERS OF THE LAND AND THAT THEY DO CAUSE THE PROPERTY TO BE PARTITIONED AND PLATTED IN ACCORDANCE WITH THE PROVISIONS OF CHAPTER 92, OREGON REVISED STATUTES AND IN ACCORDANCE WITH PLANNING APPROVAL FILE #2003-083, DOUGLAS COUNTY, PLANNING DEPARTMENT AND THEY ALSO DO CREATE FOR THE BENEFIT OF PARCEL 2 OF THIS PARTITION AND PARCEL 1 PER LAND PARTITION #1997-0092 THE 25 FOOT WIDE ACCESS AND UTILITY EASEMENT, FOR THE BENEFIT OF PARCEL 2 OF THIS PARTITION, THE DRAINFIELD EASEMENT AND FOR THE BENEFIT OF PARCEL 1 OF LAND PARTITION #1997-0092 THE 5' WIDE WATER AND POWER LINE EASEMENT WHICH INCLUDES THE 13' X 16' PUMP HOUSE AS SHOWN IN DETAIL "A". THE OWNERS DO ALSO CREATE THE 25 FOOT ACCESS EASEMENT AND DRAINFIELD EASEMENT FOR THE BENEFIT OF PARCEL 3 AS SHOWN IN DETAIL "B".

John D. Thennes
 JOHN D. THENNES

Pamela J. Thennes
 PAMELA J. THENNES

WATER: WELL
 SEWER: SEPTIC SYSTEM
 ZONING: FF, TR, F3
 COMP. PLAN: FFT, TL
 100 YR. PARCEL 2: 319.8'
 100 YR. PARCEL 3: 322.7'

SURVEYORS CERTIFICATE:

I, CARL A. SWEEDEN, A REGISTERED PROFESSIONAL LAND SURVEYOR DO HEREBY CERTIFY THAT I HAVE CORRECTLY SURVEYED AND MARKED THE LAND SHOWN HEREON AS PARCEL 2 AND 3 AND THAT PARCEL 1 PER LAND PARTITION #1997-0092 HAS NOT BEEN SURVEYED NOR MARKED IN ACCORDANCE WITH OREGON REVISED STATUTES, CHAPTER 92.

Carl A. Sweeden
 CARL A. SWEEDEN LS 2752

LEGAL DESCRIPTION:

PARCEL 1 OF INSTRUMENT #97-17686, DOUGLAS COUNTY, OREGON DEEDS AND RECORDS.

APPROVALS:

Randy Wan 5-17-04
 DOUGLAS COUNTY SURVEYOR DATE

Keith L. Cubic 5/14/04
 DIRECTOR, PLANNING DEPT. DATE

I HEREBY CERTIFY THAT ALL TAXES AND SPECIAL ASSESSMENTS OR OTHER CHARGES REQUIRED BY LAW HAVE BEEN PAID.

Sandra K. Coore 5/17/04
 DOUGLAS COUNTY TAX COLLECTOR DATE

2004-012336
 FILED THIS 18th DAY OF MAY, 2004 2:28 P.M.

Barbara E. Nielsen 5-18-04
 COUNTY CLERK DEPUTY DATE

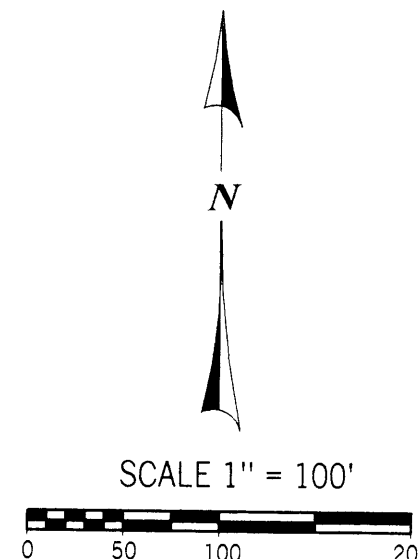

LEGEND:

- o FD 3/4" IRON ROD CRRW MONUMENT UNLESS NOTED OTHERWISE
- ∕ FD 5/8" X 30" I. ROD *SWEEDEN LS 2752*
- SET 5/8" X 30" IRON ROD W/ RED PLASTIC CAP *SWEEDEN LS 2752*
- ▲ COMPUTED POINT, NOTHING FOUND OR SET
- () RECORD PER CO. RD. #33 RECORD, FEB. 1963, SHTS 15 & 16 OF 24
- ()R1 RECORD PER LAND PARTITION #1997-0092
- ()R2 RECORD PER M 103-11 A & B
- ()R3 RECORD PER M 98-42
- MEASURED EQUALS M 142-12 UNLESS NOTED

EASEMENT LINE DATA

LINE	BEARING	DIST.
1	S 24°30'49"E	91.43'
2	S 46°04'23"E	55.68'
3	S 28°01'15"E	45.19'
4	S 6°42'27"W	61.29'
5	S 27°03'26"W	90.33'
6	N 0°00'00"E	83.18'
7	N 90°00'00"E	75.00'
8	S 0°00'00"E	80.00'
9	N 90°00'00"W	75.00'

EASEMENT DETAIL "A"
 NO SCALE

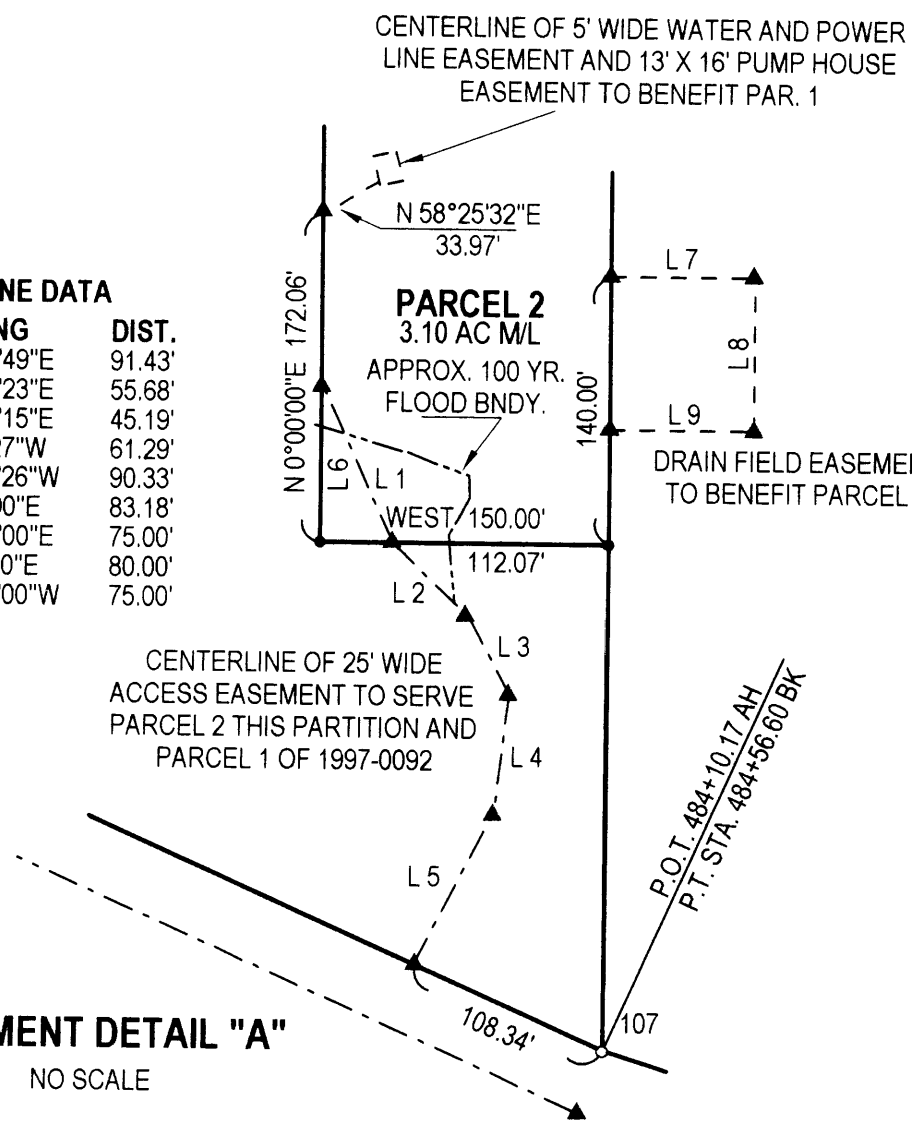

EASEMENT DETAIL "B"
 NO SCALE

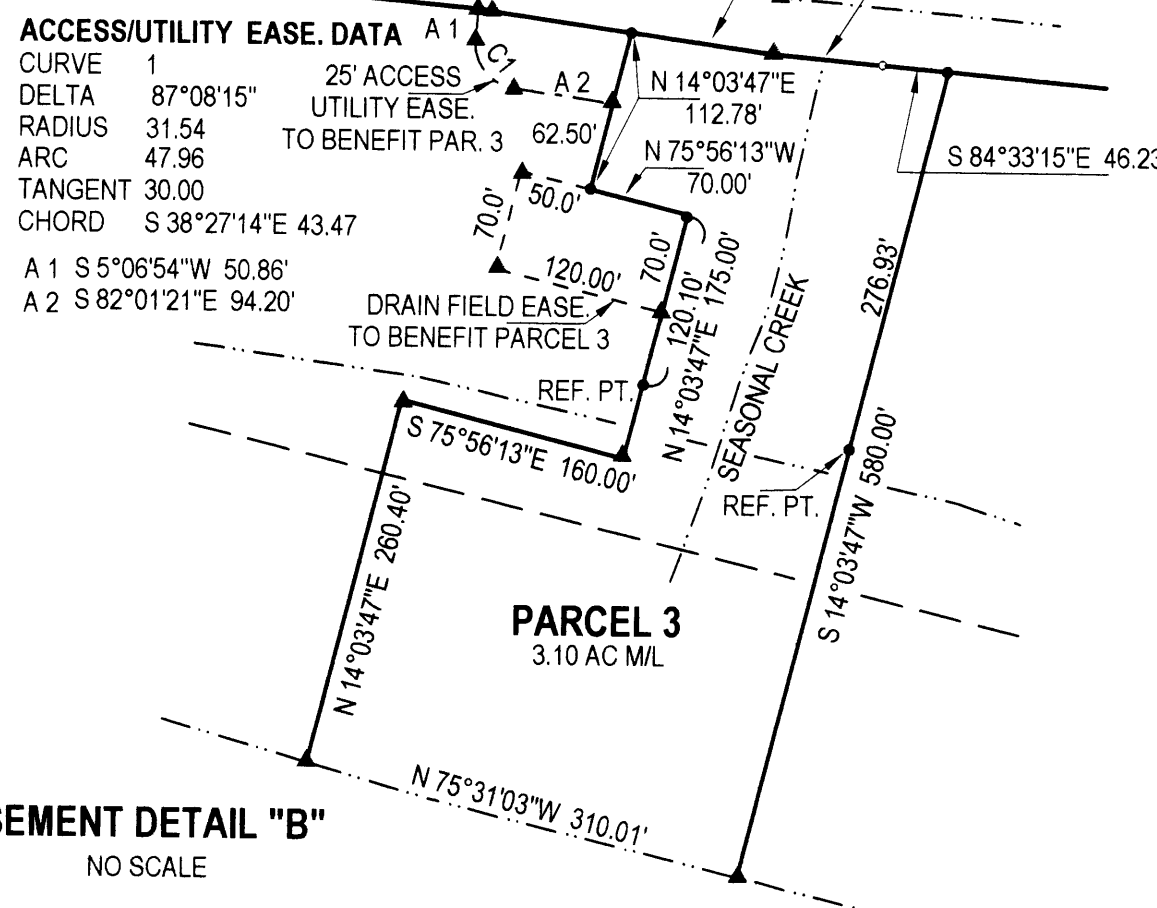

NARRATIVE:

THIS SURVEY AND PARTITION WAS COMPLETED AT THE REQUEST OF THE OWNERS SHOWN TO MARK THE BOUNDARY OF PARCELS 2 & 3 PER PLANNING FILE #03-083 AND IS BASED ON SURVEY M 142-12, A SURVEY OF PARCEL 2, LAND PARTITION PLAT #1997-0092, A NON-SURVEYED LAND PARTITION PLAT PRODUCED BY THIS FIRM IN 1997. IN SURVEY M 142-12, TYEE ROAD #33 RIGHT OF WAY MONUMENTS WERE LOCATED AND TIED IN A CLOSED LOOP TRAVERSE AS PARCEL 2 PER PLAT #1997-0092 WAS DESCRIBED BEGINNING AT RIGHT OF WAY STATION PT 484+56.60 AND THE BEARINGS WERE BASED ON THE CENTERLINE BEARING OF THE COUNTY ROAD. TO COMPLETE THIS LAND PARTITION MORE TYEE ROAD RIGHT OF WAY MONUMENTS WERE FOUND, TIED AND USED TO ESTABLISH THE WEST LINE OF THAT LAND DESCRIBED AS PARCEL 3 PER INSTRUMENT #2001-9988. WITH THIS COMPLETE THE BOUNDARY OF PARCEL 2 AND PARCEL 3 OF THIS LAND PARTITION WERE ESTABLISHED AS SHOWN. RIGHT OF WAY MONUMENTS AT POINTS "A" AND "B" WERE USED AS THE BASIS OF BEARING FOR THIS SURVEY AND CENTERLINE POINT "D" COMPUTED AT 30.0' FROM "B" ON LINE BETWEEN POINTS "B" & "C". THE COUNTY ROAD RECORD WAS THEN USED TO ESTABLISH THE RIGHT OF WAY OF THE COUNTY ROAD USING THIS COMPUTED CENTERLINE POINT. OTHER FOUND MONUMENTS EAST AND WEST OF "A" AND "B" ARE SHOWN IN RELATION TO THE COMPUTED RIGHT OF WAY POSITIONS WITH THE FOUND 3/4" IRON ROD AT STATION 451+32.72 HELD FOR STATION.

FIELD CREW: C. SWEEDEN & R. MERCER
 EQUIPMENT USED: NIKON DTM-521 W/ SUPPORT
 MAPPING AND CALCULATIONS: C. SWEEDEN

ACKNOWLEDGEMENTS:

STATE OF OREGON)
 COUNTY OF DOUGLAS)

THERE PERSONALLY APPEARED BEFORE ME JOHN D. AND PAMELA J. THENNESS WHO IS KNOWN TO ME TO BE THE IDENTICAL INDIVIDUAL WHO EXECUTED THE FORGOING INSTRUMENT AND WHO DOES HEREBY ACKNOWLEDGE SAID INSTRUMENT TO BE THEIR VOLUNTARY ACT AND DEED.

THIS INSTRUMENT WAS ACKNOWLEDGED BEFORE ME ON THIS:

19 DAY OF April, 2004.

Stacey R LeFevre *Stacey R LeFevre*
 NOTARY PUBLIC - OREGON (PRINTED NAME) (SIGNATURE)

355887 March 20, 2006
 COMMISSION NO. MY COMMISSION EXPIRES

OWNERS / PARTITIONERS:

JOHN D. & PAMELA J. THENNES
 8757 TYEE ROAD
 OAKLAND, OREGON 97462



Sweeden
 Land Surveying
 Carl A. Sweeden
 P.L.S.

5211 Cole Road
 Oakland, Ore. 97462
 Tel. 541-459-9523

2004-0022 B

2004-0022 B