

OFFICE OF THE
DOUGLAS COUNTY SURVEYOR

Station: U 609 T 32 S, R 6W, Sec 35
Set By (Agency): OSHD
Date Set: 1966
Recovered By JP-RS
Date Recovered 2-4-82
Recovered By _____
Date Recovered _____
Recovered By _____
Date Recovered _____

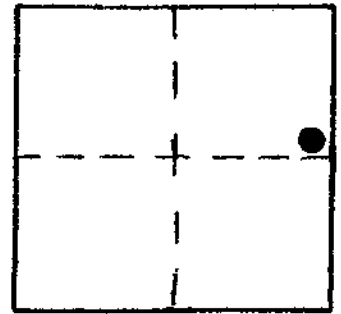

U-109

VERTICAL CONTROL

Elevation: 1541.398 NGS Line # _____ USGS Line # _____ OSHD Line # _____
Precision: 2nd Agency: DCSO Proj. # 2006 Date: 1973

HORIZONTAL CONTROL

South Zone State Plane Coordinates: Y(Northing) _____ X(Easting) _____
Precision: _____ Agency: _____ Proj. # _____ Date: _____
Approximate Geographic Position: Latitude _____ Longitude _____

DESCRIPTION and TO REACH

Found: A standard OSHD disk marked "U 609 11-66" set flush on curb of overpass. Sta. is 0.6 ft. above and 0.4 ft. Northerly of bridge deck and expansion joint and 0.3 ft. from edge of curb.

To reach: Station is located on the Glendale interchange overpass (Exit #88). Said station is at the Northerly end and on the Westerly side of overpass in the South bound land of Interstate 5.

SKETCH

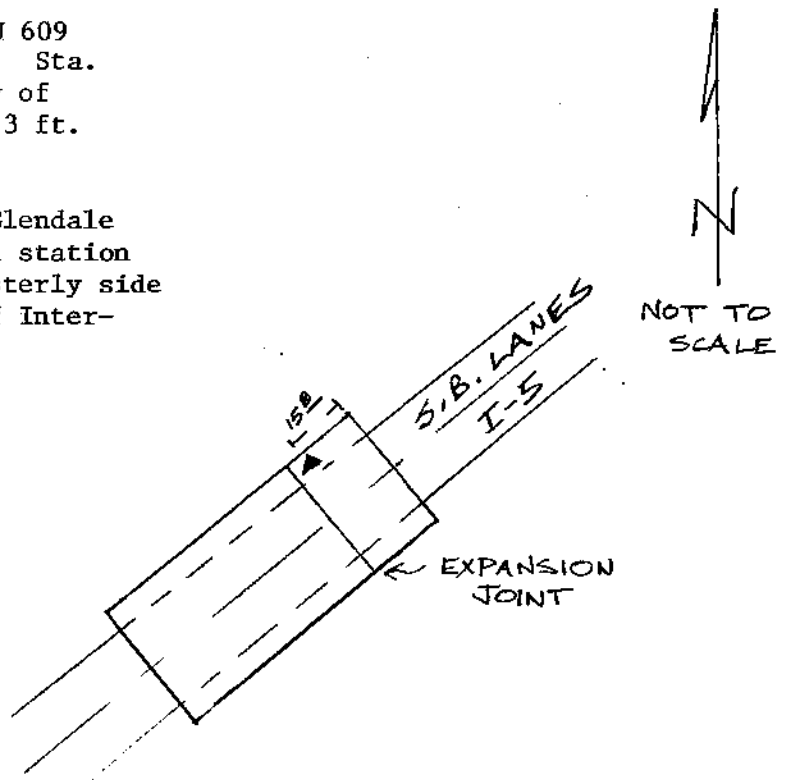

Reference Marks:

Note: For further information, contact the Douglas County Surveyor's Office, Room 205 Douglas County Justice Building, Roseburg, OR 97470. Phone 440-4278. Douglas County residents outside the Roseburg calling area, dial toll free 1-800-452-0991.